

# MODEL 2642

## 3-Phase Monitor

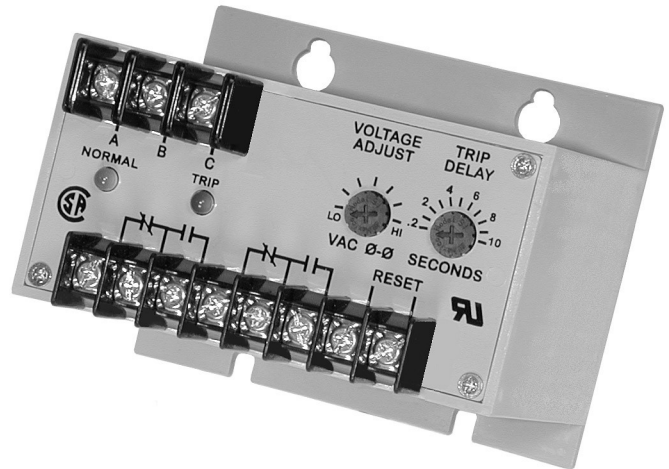

- Detects Phase Loss, Low Voltage and Phase Reversal
- Adjustable Trip Delay
- Automatic or Manual Reset
- DPDT Output Contacts



### DESCRIPTION

The Model 2642 3-Phase Monitor protects electrical equipment by sensing phase loss, low voltage and reverse phase conditions. This device uses a combination of voltage and phase angle sensing, and will detect a phase loss even when regenerated voltages are present.

The Model 2642 is fail-safe; the output contacts will transfer when correct power is applied, and trip out on any fault condition or complete loss of power. Each of five voltage versions can be adjusted throughout a wide operating range. An adjustable trip delay timer prevents nuisance tripping caused by momentary voltage dips.

The DPDT output contacts allow the Model 2642 to be used in control circuits and alarm circuits. The automatic reset can be converted to a manual reset by adding a normally closed switch.

### DIMENSIONS

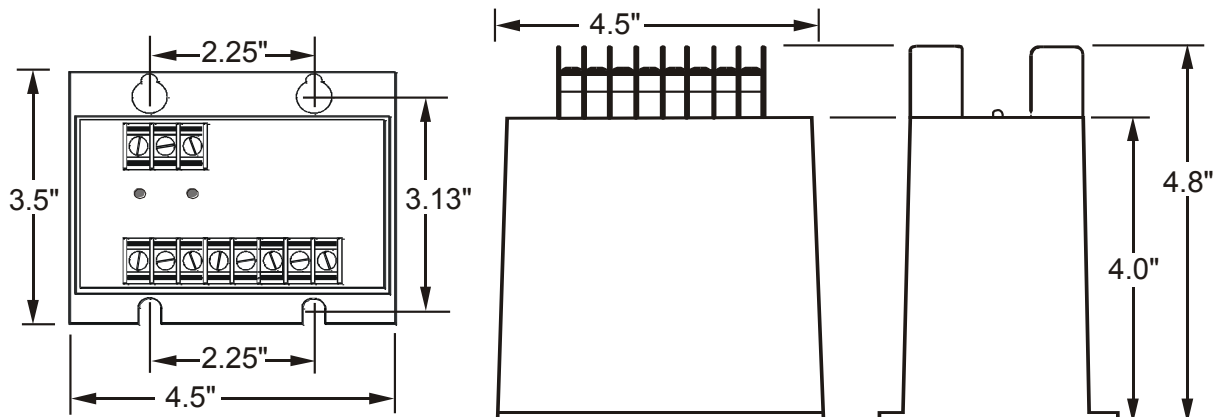

### SPECIFICATIONS

MODEL	A2642	B2642	C2642	D2642	EX2642
Nominal AC Voltage (phase to phase)	120VAC	208/240VAC	480VAC	575VAC	380VAC
Adjustment Range	85-125V	160-260V	380-500V	450-600V	300-400V
Frequency	60Hz	60Hz	60Hz	60Hz	50Hz
Power Consumption	0.25W	0.5W	1.5W	2.5W	1.5W
Transient Protection	2500 VRMS for 10ms				
Repeat Accuracy	± 0.5% of setpoint (fixed conditions)				
Response Time	Adjustable 0.2 to 10 seconds ±5%				
Reset Time	0.15 seconds				
Dead Band	Approximately 2%				
Output Contacts	DPDT 10 amps at 240VAC resistive				
Expected Relay Life	Mech: 10 million operations Elec: 100,000 operations at rated load				
Operating Temp	- 20° to +131° F				
Humidity Tolerance	0 - 97% w/o condensation				
Enclosure Material	ABS plastic				
Mounting	Surface				
Weight	12 oz.				
Agency Approvals	UL Recognized; CSA Certified				



**TIME MARK**  
CORPORATION

11/2011  
© 2011 TIME MARK CORPORATION

TIME MARK is a division of  AEMT, Inc.

# MODEL 2642 3-Phase Monitor

READ ALL INSTRUCTIONS BEFORE INSTALLING, OPERATING OR SERVICING THIS DEVICE.  
KEEP THIS DATA SHEET FOR FUTURE REFERENCE.

## GENERAL SAFETY

POTENTIALLY HAZARDOUS VOLTAGES ARE PRESENT AT THE TERMINALS OF THE MODEL 2642.  
ALL ELECTRICAL POWER SHOULD BE REMOVED WHEN CONNECTING OR DISCONNECTING WIRING.  
THIS DEVICE SHOULD BE INSTALLED AND SERVICED BY QUALIFIED PERSONNEL.

## Installation Instructions

### INSTALLATION

Turn both adjustment control potentiometers fully counter-clockwise.

Connect the 3-phase wires to the terminals marked **A**, **B** and **C**.

Connect the control wires to one set of the terminals with the relay contact markings. The contact markings on the unit are the failed or tripped condition of the contacts. The second set of output terminals can be used in an alarm circuit or in the control circuit of a second load. Refer to the TYPICAL APPLICATION drawing.

As provided, the Model 2642 has an Automatic Reset. If you prefer a Manual Reset, install a normally-closed push button across the terminals marked RESET. The Manual Reset leads should be kept as short as possible.

Apply power. If the contacts do not transfer when power is applied (TRIPPED indicator off; NORMAL indicator on), check that all three phases are present and of the correct voltage.

If all phases are correct, remove power from the unit, reverse any two of the **A**, **B** or **C** terminal wires (*phase rotation is reversed*), and re-apply power. The contacts should then transfer.

### ADJUSTMENT

**NOTE:** When adjusting the Model 2642 you may wish to jumper the control circuit contacts (& disconnect the alarm contacts, if used) to prevent the unit from cycling the load.

Rotate the VOLTAGE ADJUST pot clock-wise until the unit trips (NORMAL indicator off, TRIP indicator on).

Slowly turn the VOLTAGE ADJUST pot counter-clockwise until the unit resets (TRIP indicator off; NORMAL indicator on).

Set the TRIP DELAY adjustment to the desired amount of delay to prevent nuisance trips.

These adjustment settings will be correct for most applications. Should nuisance trips occur, even with the TRIP DELAY set, turn the VOLTAGE ADJUST pot slightly farther counter-clockwise. Any adjustments should be made in very small increments.

### TYPICAL APPLICATION

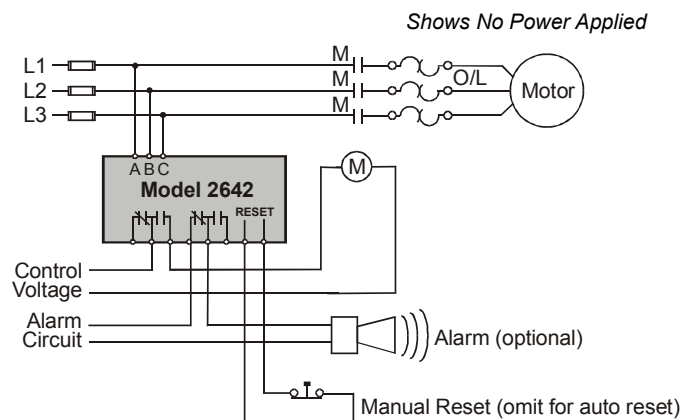

### WARRANTY

This product is warranted to be free from defects in materials and workmanship, and is covered by our exclusive **5-year Unconditional Warranty**. Should this device fail to operate for any reason, we will repair it for five years from the date of manufacture. For complete warranty details, see the *Terms and Conditions of Sales* page in the front section of the Time Mark catalog or contact Time Mark at 1-800-862-2875.



**TIME MARK**  
CORPORATION

11/2011

© 2011 TIME MARK CORPORATION

TIME MARK is a division of  **AEMT, Inc.**